

Installation Manual  
Socket and Cover Plate 0111  
Snowmelt Sensor 0110  
Version 1.10



SNO-0111  
SNO-0110

## INTRODUCTION

Together the SNO-0110 (sensor & cable) and the SNO-0111 (socket and cover plate) make up the sensor portions of the HBX Snowmelt System. The SNO-0110 snow/ice sensor is an optical design that is capable of sensing snow conditions. This allows the user to set a preferred starting condition for the snowmelt system. The SNO-0110 is design to be mounted in the slab however because of the optical design it can also be remotely installed.

The SNO-0111 socket and cover plate allows for the concrete, asphalt, etc. to be poured prior to the installation of the SNO-1000 Control, the SNO-0100 Module, and the SNO-0110 snow/ice sensor.

## GETTING STARTED

This manual will help with the installation, parameter setting, troubleshooting and general maintenance requirements for the controller, and the module. To guarantee the safe and reliable operation of your snowmelt system, you must first read this manual in detail and take particular note to any and all warnings.



**Only suitably qualified individuals with formal training in electrical and HVAC controls should attempt the installation of this equipment. Incorrect wiring and installation will affect the warranty provided with this unit. Wiring must be completed in accordance with the codes and practices applicable to the jurisdiction for the actual installation.**

## SYMBOLS



### Point of Interest

This point clarifies pertinent information, or brings your attention to an action that may have adverse effects on the installation process.



### Moderate Hazard

This action may cause personal injury or have adverse effects on the installation process if handled incorrectly.

## RECEIVING, UNPACKING, INSPECTION AND STORAGE

The SNO-0110 has gone through rigorous quality control tests at the factory before shipment. After receipt and before installation perform the following checks:

### Receipt

After receiving, inspect the unit for any possible physical damage that may have occurred during transportation.

### Inspection

After unpacking the unit make sure the boxes contain:

SNO-0110 Package:

- Optical snowmelt sensor
- 100 feet of 22 awg 2 pair shielded cable

SNO-0111 Package:

- Sensor socket
- Cover plate (dud sensor)
- 4 x Stainless steel 4 x 25mm machine screws

**GENERAL TECHNICAL DATA****Materials:**

Polycarbonate and brass

**Weight:**

0.45 KG (1.00 lb)

**Socket Dimensions:**

140mm W x 103mm H x 140mm D

**Sensor Dimensions:**

100mm W x 38mm H x 100mm D

**ETL Listings:**

Meets CSA C22.2 No. 24

Meets UL Standard 873

ETL Control No. 3068143

**Nameplate Information:**

The exterior label contains specific information unique to your HBX Snowmelt Sensor and identifies some of the basic features. The label displays the serial number which will match the serial number on the SNO-1000 Control, the lot number, the bar code and the product's ETL number.

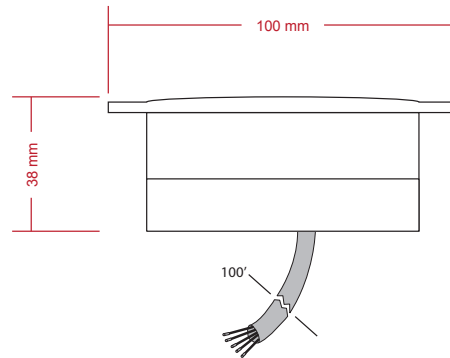
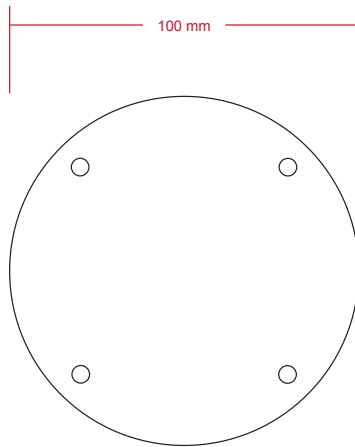

Top View

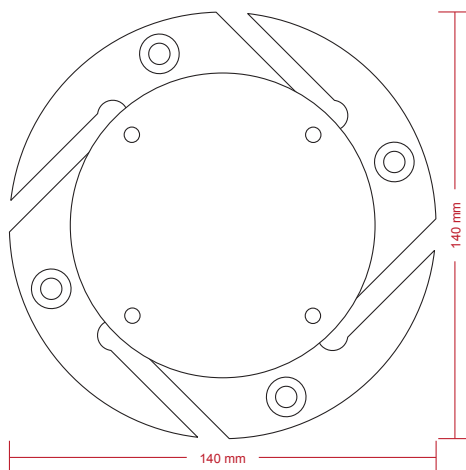

Side View

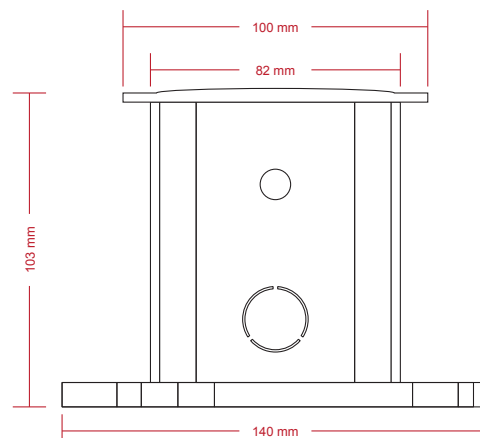

Bottom View

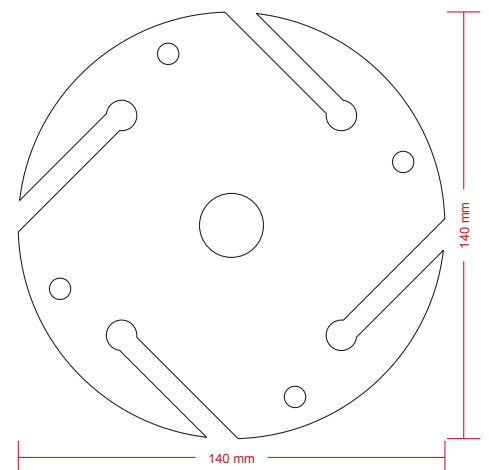

## WIRING, LOCATION & INSTALLATION



**CAUTION:** Proper sensor installation is key to a properly performing snowmelt system. All applicable electrical codes should be followed.

### Sensor Wire

Take special care that the sensor wire is not run with any high voltage wiring as this may result in faulty readings. The sensor is supplied with 100 feet of 22 awg shielded cable. If the sensor is more than 100 feet from the control extend the wire from the end of the sensor wire. **DO NOT** shorten the original sensor wire then extend its length over 100 feet. When extending the cable use 18awg shielded cable. If possible, use 2 pair shielded 18 awg for best results. You must also extend the shield wire and attach it to the same point as the black wire on the SNO-0100. If you don't the temperature sensor in the SNO-0110 will not work properly.



**Make sure to use all 100 feet of cable supplied if control is further than 100 feet from the sensor.**



**Note:** For applicable applications the snow/ice sensor can be wired up through a junction box to the control.

### Slab Location

Installing the sensor at the correct location in the slab is critical for a properly functioning snow/ice melting system. The sensor should be located where snowfall is normal and not affected by surrounding buildings.

The sensor location should also be halfway between the two heating pipes that are installed in the slab. There is a thermistor built into the sensor that senses the slab temperature at all times. Keeping the sensor away from pipes in the slab ensures the accurate operation of your snow/ice melting system.

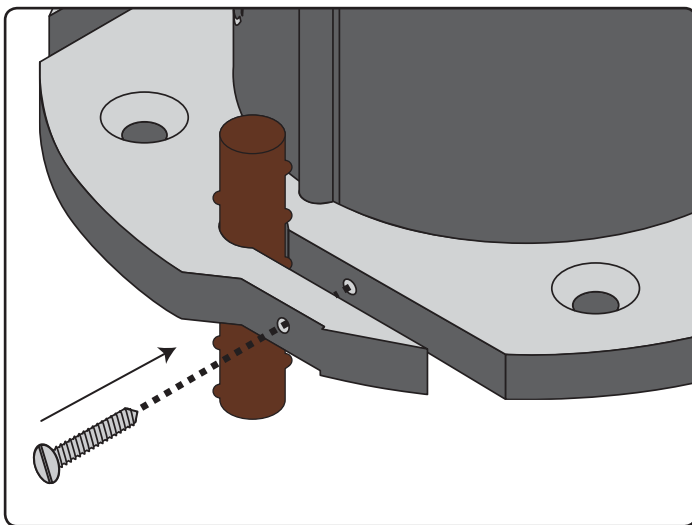

### Mounting the Socket

When mounting the socket and cover plate in the snowmelt slab use rebar mounted in the soil below to level the socket and cover plate so that the cover plate is level with the finished grade of the snow melting surface.



**Failure to mount the socket properly may result in incorrect or faulty sensor readings.**

When the socket and cover plate are level use a screw to tighten the socket onto the rebar as pictured (left).

### Ramp Mounting

The socket and cover plate can also be mounted on a ramp. Make sure to locate the socket and cover plate near the bottom of the ramp. This will allow for proper ice melting when the melted snow flows down.

## Remote Sensor Location

The optical nature of the snow/ice sensor allows for mounting somewhere other than the slab (i.e. a roof or fence post). This is possible, but take special care that it is not mounted in an area where the surroundings cause an abnormal amount of snow fall.



**When remote mounting the sensor an external slab sensor must be used in order for the control to be able to read the slab temperature. The temperature sensor on the snow/ice sensor will no longer be used.**

You must select the control setting for remote slab to yes (i.e. 'Y'). This will let the control know that you have remotely mounted the snow/ice sensor. See the SNO-1000/0100 Manual for more information. See drawing 2 for the correct wiring of a remote slab sensor.

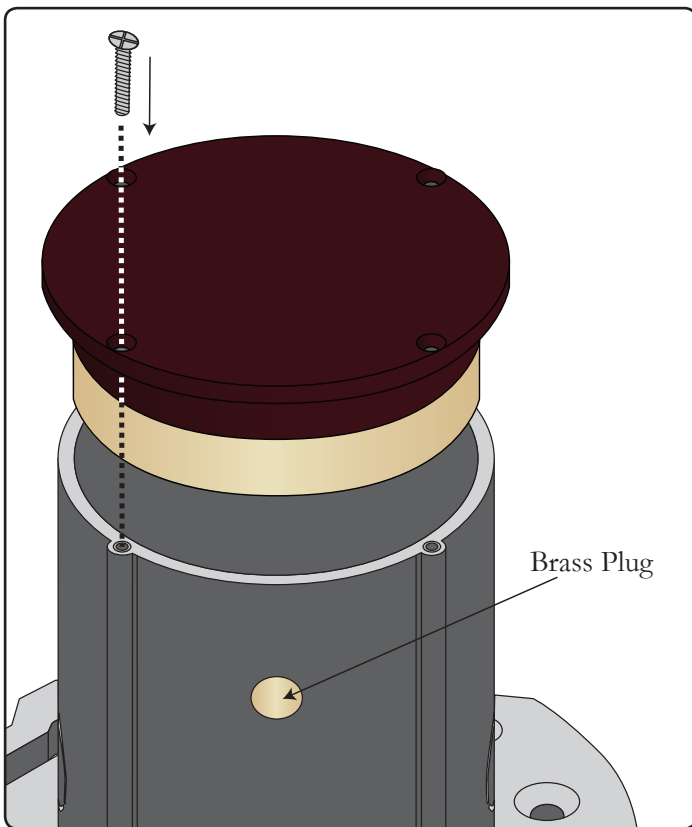

### Brass Plugs

On the socket there are 4 brass plugs. These plugs are designed to make contact with the brass ring on the sensor so the sensor can get proper slab temperatures. Take care not to press these plugs in or out as they are properly set at the factory. Manipulation of the plugs may result in the sensor not fitting properly in the socket.

Take special care to clean the brass surfaces on the inside of the socket. Making sure to clean any concrete that may have accumulated on them. Failure to do so may result in the sensor not making proper contact and not reading the slab temperature properly.

### Installing the Sensor

Once the snow melting surface is finished you can install the snow/ice sensor. Clean any excess debris from inside the socket. Fish the snow/ice sensor wire through the pre-installed pipe. Make sure to leave a little bit of slack in the wire.



**Take special care to align the screw holes from the snow/ice sensor to those on the socket (pictured left). Once the sensor is pressed into place prying up the sensor to line up the holes will result in damage to the sensor and, potentially, the socket.**

Once the snow/ice sensor is properly inserted into the socket put the four screws back in place to secure it.

## MAINTENANCE

In order to ensure the long term accuracy of your snow/ice melting system you should clear away any mud, rocks, or other debris that might obstruct the sensors optics.

In the unlikely event that the sensor becomes inoperable carefully remove it from the socket and follow the installation procedure to install a new sensor.

## SNO-0110 - DRAWING 001 REGULAR SNOW/ICE SENSOR WIRING

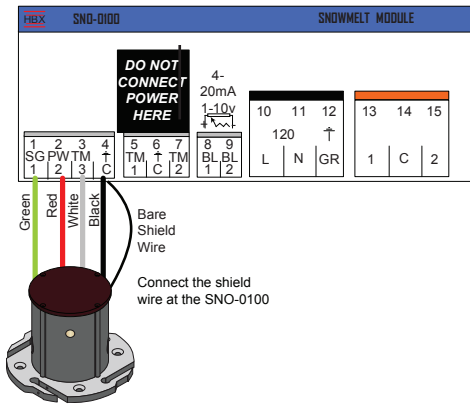

## SNO-0110 - DRAWING 002 REMOTE INSTALL - SNOW/ICE SENSOR

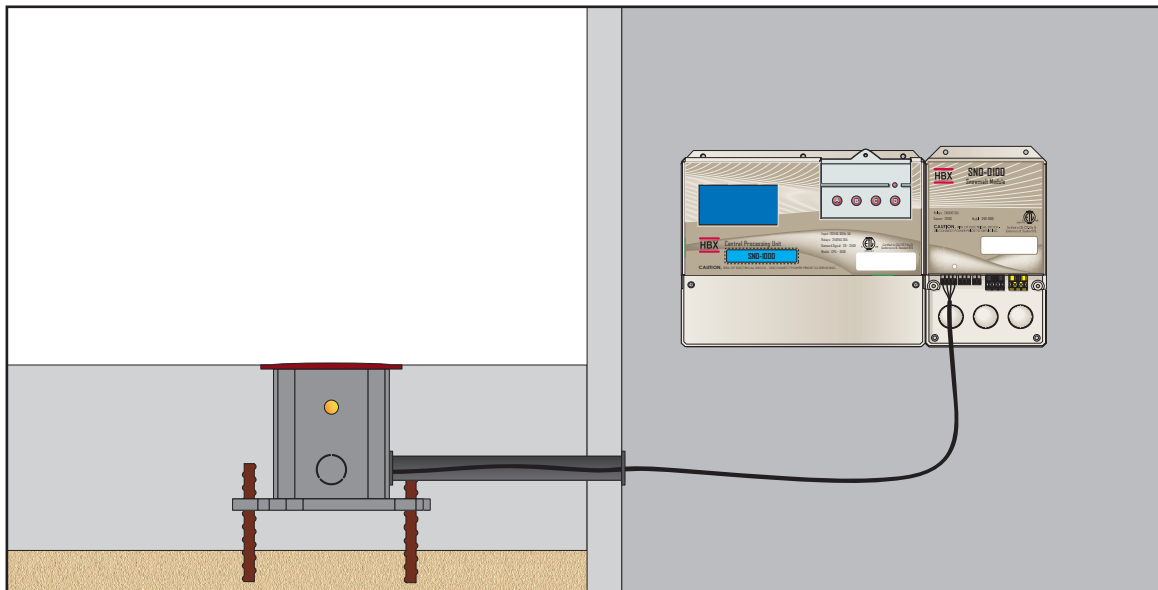
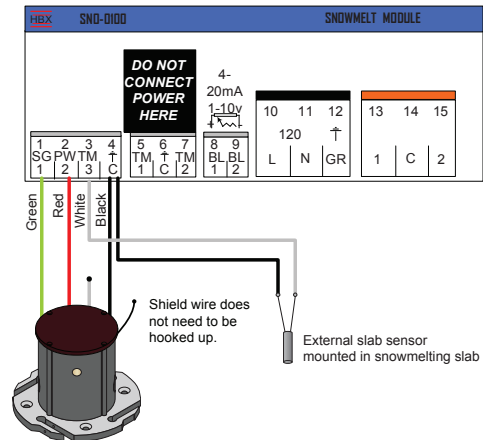

These are not engineered drawings and do not necessarily include all the components for an entire system. They are intended as representations of how the Sensor may be wired into a control for a sample application. It is the responsibility of the installer to seek professional advice and/or install the system to meet all necessary codes for the jurisdiction of the actual installation.

**Limited Warranty**

HBX Controls warrants each of its products to be free from defects in workmanship and materials under normal use and service for a period of 24 months from date of manufacture or 12 months from date of purchase from an HBX Authorized Dealer, if within the above documented period after date of manufacture. The SNO-0110 snow/ice sensor is guaranteed under a 3 year, parts only, warranty.

If the product proves to be defective within the applicable warranty period, HBX on its sole discretion will repair or replace said product. Replacement product may be new or refurbished of equivalent or better specifications, relative to the defective product. Replacement product need not be of identical design or model. Any repair or replacement product pursuant to this warranty shall be warranted for not less than 90 days from date of such repair, irrespective of any earlier expiration of original warranty period. When HBX provides replacement, the defective product becomes the property of HBX Controls.

Warranty Service, within the applicable warranty period, may be obtained by contacting your nearest HBX Controls office via the original Authorized Agent and requesting a Return Material Authorization Number (RMA #). Proof of purchase in the form a dated invoice/receipt must be provided to expedite the issuance of a Factory RMA.

After an RMA number has been issued, the defective product must be packaged securely in the original or other suitable shipping package to ensure that it will not be damaged in transit. The RMA number must be visible on the outside of the package and a copy included inside the package. The package must be mailed or otherwise shipped back to HBX with all costs of mailing/shipping/insurance prepaid by the warranty claimant.

Any package/s returned to HBX without an approved and visible RMA number will be rejected and shipped back to purchaser at purchaser's expense. HBX reserves the right, if deemed necessary, to charge a reasonable levy for costs incurred, additional to mailing or shipping costs.

**Limitation of Warranties**

If the HBX product does not operate as warranted above the purchasers sole remedy shall be, at HBX's option, repair or replacement. The foregoing warranties and remedies are exclusive and in lieu of all other warranties, expressed or implied, either in fact or by operation of law, statutory or otherwise, including warranties of merchantability and fitness for a particular purpose/application. HBX neither assumes nor authorizes any other person to assume for it any other liability in connection with the sale, installation maintenance or use of HBX Controls products.

HBX shall not be liable under this warranty; if its testing and examination discloses that the alleged defect in the product does not exist or was caused by the purchasers or third persons misuse, neglect, improper installation or testing, unauthorized attempts to repair or any other cause beyond the range of intended use, or by accident, fire, lightning or other hazard.

**Limitation of Liability**

In no event will HBX be liable for any damages, including loss of data, loss of profits, costs of cover or other incidental, consequential or indirect damages arising out of the installation, maintenance, commissioning, performance, failure or interruption of an HBX product, however caused and on any theory of liability. This limitation will apply even if HBX has been advised of the possibility of such damage.

**Local Law**

This limited warranty statement gives the purchaser specific legal rights. The purchaser may also have other rights which vary from state to state in the United States, from Province to Province in Canada and from Country to Country elsewhere in the world.

To the extent this Limited Warranty Statement is inconsistent with local law, this statement shall be deemed modified to be consistent with such local law. Under such local law, certain disclaimers and limitations of this statement may not apply to the purchaser. For example, some states in the United States, as well as some governments outside the United States (including Canadian Provinces), may:

Preclude the disclaimers and limitations in this statement from limiting the statutory rights of a consumer (e.g. United Kingdom);

Otherwise restrict the ability of a manufacturer to enforce such disclaimers or limitations; or grant the purchaser additional warranty rights which the manufacturer cannot disclaim, or not allow limitations on the duration of implied warranties.

Phone: +1 (403) 720-0029 Fax: +1 (403) 720-0054  
Email: [info@hbxcontrols.com](mailto:info@hbxcontrols.com) Web: [www.hbxcontrols.com](http://www.hbxcontrols.com)

v3.3

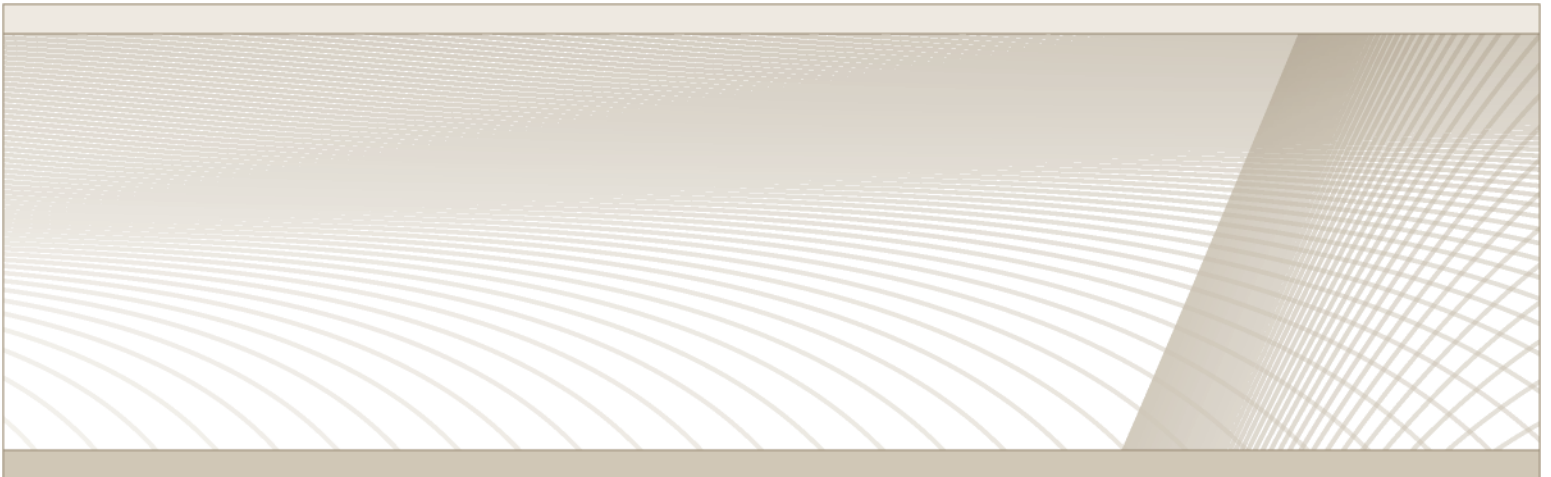

HBX Control Systems Inc.  
4516 - 112<sup>th</sup> Avenue SE  
Calgary, AB T2C 2K2

© HBX Control Systems Inc. 2011